

1550nm Multi-Junction Pulsed Laser Diodes*

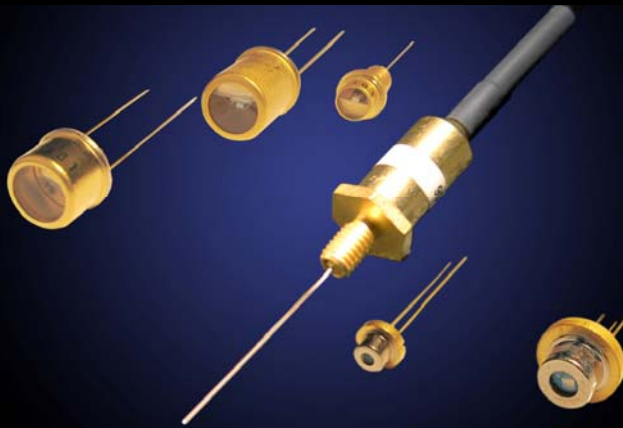

"Eye Safe"

High Efficiency

Stable output from -40°C to +85°C

Single and stacked devices up to 60Watts

Hermetic package

RoHS Compliant

Applications:

- Ranging
- Surveying equipment
- Friend or foe identification

**Patent Pending*

CVLM Series Characteristics @ 25°C

Parameter	Symbol	Min	Typ	Max	Unit
Peak Wavelength	λ	1530	1550	1570	nm
Spectral Width	$\Delta\lambda$		12		nm
Temperature Coefficient of Wavelength	$\Delta\lambda/\Delta T$		0.4		nm/°C
Beam Spread	FWHM		12 x 37		degrees
Operating Temperature	T_o	-40		+85	°C
Pulse Width	Pw			150	ns

CVLM 57 Series

Parameters	Symbol	CVLM57	CVLM2S57 ³	CVLM3S57 ³	Units
Peak Power (min)	P_o	25	40	60	Watts
Peak Power (Fiber) ¹	P_f	13	20	30	Watts
Peak Forward Current	I_f	20	20	20	Amps
Threshold Current (typ)	I_{th}	2.5	2.5	2.5	Amps
Number of Diodes		1	2	3	
Emitting Area (typ)		10 x 350	120 x 350	240 x 350	Microns
Fiber (core size)		400	400	400	Microns
Duty Factor ²	DF	0.07	0.07	0.07	%

Notes: Devices are supplied case negative unless otherwise specified.

1 Fiber: 400 micron 0.37NA Hard Clad Silica

2 Heat sinking required

3 Estimated data; to be defined

Package Drawings

TO5F (Non-Hermetic) Package

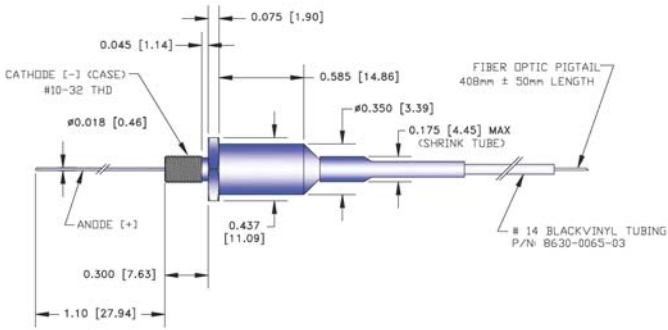

9mm Package

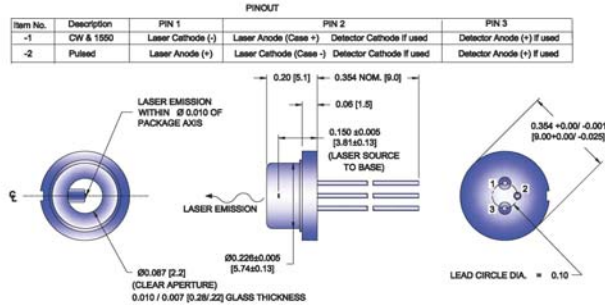

TO18T Package

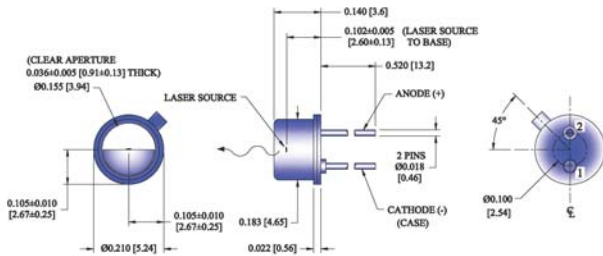

Other package options available. Dimensions: inches [mm]

TO18C Package

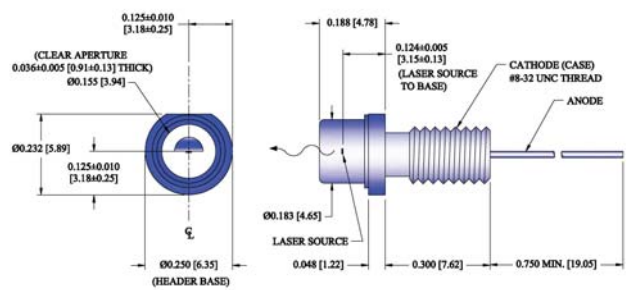

Ordering Information

Products can be ordered directly from Laser Diode Incorporated or its representatives. When ordering, refer to the information below. For a complete listing of representatives, visit our website at www.laserdiode.com

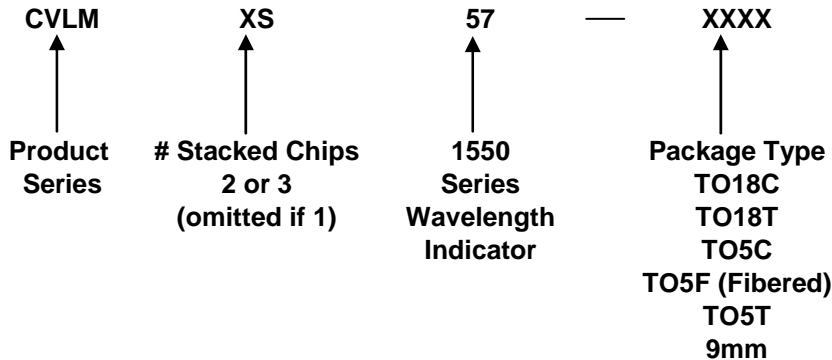

Example: **CVLM 2S57-TO18C**
Pulsed Laser, Multi-Stacked, 20W 1550 +/-15nm, TO18C Package

NOTE: Not all options are available for all packages. Other power options are available. Fiber pigtailed versions of all lasers are available. Output is typically 50% of rated power.

Safety:
Caution: Laser light emitted from any diode laser may be harmful to the human eye. Avoid looking directly into the diode laser aperture when the device is in operation.
Class 3B laser

ESD Caution:
Handle diode lasers with extreme care to prevent electrostatic discharge. Follow ESD precautions when handling devices.

Warranty:
Please refer to your product purchase agreement for complete details or check with your Laser Diode sales representative.

Notice:
LDI reserves the right to make changes to the products or information contained herein without notice. No Liability is assumed as a result of their use or application.